



SPECIFICATION SHEET

# 2933XP



Xform  
Performance

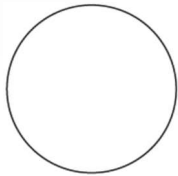

Front

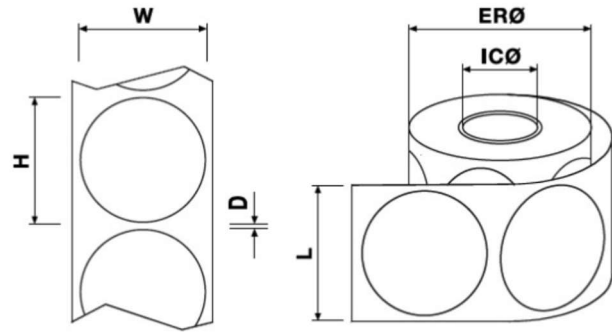

Product Description:	2933XP,8.2,2KR DE,Plain
Part N°:	10155067
Label Dimensions (W*H):	Ø 33 mm / 1.30"
Distance between labels (D):	2.45 mm/0.10"
Liner Width (L):	35.45 mm / 1.40"
External Roll Diameter (ER):	Ø181 mm /7.13"
Inner Core Diameter (IC):	Ø76.2 mm / 3"
Face Sheet:	Premium Grade Paper
Adhesive:	All Purpose Grade
Labels per roll:	2,000 Pcs
Labels per case:	20,000Pcs
Approx. Weight roll:	0.730kg /1.61 lbs.
Approx. Weight case:	8.40kg / 18.50lbs.
Frequency (MHz) ± 5%:	8.2 ±5% MHz
Electrostatic Discharge Tolerance (ESD):	4.7KV(Minimum)
*Minimal Order Quantity (MOQ)	20,000Pcs (1 carton)

Storage conditions: Keep dry but do not expose to direct sunlight

- Recommended storage temperature: 18 to 29°C Maximum temperature should not exceed 43°C
- Maximum shelf life of RF labels when stored in recommended conditions in 2 years\*\*

Cases should never be stacked more than 5 high.

\* Unless otherwise specified in contractual conditions

\*\* RF circuits have no expiry date; however the adhesive has a useful working life of 2 years from the date of manufacture

For any questions regarding this or any other labelling process contact your local Checkpoint representative.

